

SmartNode SN4170 E1/T1 PRI VoIP Gateway

User Manual



This is a Class A device and is not intended for use in a residential environment.

Sales Office: +1 (301) 975-1000
Technical Support: +1 (301) 975-1007
E-mail: support@patton.com
WWW: www.patton.com

Patton Electronics Company, Inc.

7622 Rickenbacker Drive
Gaithersburg, MD 20879 USA
tel: +1 (301) 975-1000
fax: +1 (301) 869-9293
support: +1 (301) 975-1007
web: www.patton.com
e-mail: support@patton.com

Trademark Statement

The term *SmartNode* is trademarks of Patton Electronics Company. All other trademarks presented in this document are the property of their respective owners.

Copyright © 2015–2018, Patton Electronics Company. All rights reserved.

The information in this document is subject to change without notice. Patton Electronics assumes no liability for errors that may appear in this document.

Warranty Information

The software described in this document is furnished under a license and may be used or copied only in accordance with the terms of such license.

Patton Electronics warrants all SmartNode extender components to be free from defects, and will—at our option—repair or replace the product should it fail within one year from the first date of the shipment.

This warranty is limited to defects in workmanship or materials, and does not cover customer damage, abuse or unauthorized modification. If the product fails to perform as warranted, your sole recourse shall be repair or replacement as described above.

Under no condition shall **Patton Electronics** be liable for any damages incurred by the use of this product. These damages include, but are not limited to, the following: lost profits, lost savings and incidental or consequential damages arising from the use of or inability to use this product. **Patton Electronics** specifically disclaims all other warranties, expressed or implied, and the installation or use of this product shall be deemed an acceptance of these terms by the user.

Summary Table of Contents

- 1 General Information 14
- 2 Applications Overview 19
- 3 SmartNode Installation 22
- 4 Initial Configuration 27
- 5 Contacting Patton for Assistance 36
- A Compliance Information 39
- B Specifications 42
- C Cabling 46
- D Port pin-outs 50
- E SmartNode SN4170 Factory Configuration 53
- F Reset Button Functions 55
- G End User License Agreement 58

Table of Contents

Summary Table of Contents	3
Table of Contents	4
List of Figures	7
List of Tables	8
About this guide	9
Safety when working with electricity	10
Deutsch	11
General observations	12
Typographical conventions used in this document	12
Procedures described in this manual use the following text conventions:	12
1 General Information	14
SmartNode SN4170 Overview	15
SmartNode SN4170 Rear Panel	15
SmartNode SN4170 Front Panel	18
2 Applications Overview	19
Introduction	20
Application—Convert Legacy PBX to VoIP	20
Application—Migrate from VoIP Gateway to eSBC	21
3 SmartNode Installation	22
Planning the Installation.....	23
Site log	23
Network information	23
Network Diagram	23
IP related information	23
Software tools	24
Power source	24
Location and mounting requirements	24
Installing the Patton SmartNode VoIP Gateway.....	24
Placing the SmartNode	24
Installing cables	25
4 Initial Configuration	27
Introduction	28
Connecting the SmartNode 4171 to Your Laptop PC	28
Configure the Desired IP Address	29
Connecting the SmartNode to the Network	30
Connecting SN4171/2ETH models to your PC.....	31
Configure the Desired IP Address	32
Changing the WAN IP address	33
Connecting the SmartNode to the Network	33

Loading the Configuration (optional).....	34
Additional Information	35
5 Contacting Patton for Assistance	36
Introduction	37
Contact information.....	37
Contacting Patton Technical Services for Free Support	37
Warranty Service and Returned Merchandise Authorizations (RMAs).....	37
Warranty coverage	37
RMA numbers	38
A Compliance Information	39
Compliance.....	40
EMC	40
Safety	40
Radio and TV interference	40
CE Declaration of Conformity.....	40
Authorized European Representative	40
ISDN Compliance	41
B Specifications	42
DSP.....	43
Voice Connectivity.....	43
Data Connectivity	43
Voice Processing (signalling dependent)	43
Fax and modem support.....	44
Voice Signalling.....	44
Voice Routing—session gateway.....	44
IP Services	45
Management	45
System.....	45
Physical	45
C Cabling	46
Introduction.....	47
Serial Console.....	47
Ethernet	48
ISDN PRI (E1/T1)	49
D Port pin-outs	50
Introduction.....	51
Console port.....	51
Ethernet	51
ISDN PRI (E1/T1) Port Pin-outs.....	52
E SmartNode SN4170 Factory Configuration	53
Introduction.....	54
F Reset Button Functions	55

Introduction	56
Resetting the SmartNode device when it is operating and the Power LED is lit.....	56
Resetting the SmartNode device when it is initially powered off.....	57
G End User License Agreement	58
End User License Agreement.....	59
1. Definitions	59
2. Title	59
3. Term	59
4. Grant of License	59
5. Warranty	60
6. Termination	60
7. Notices	60
8. Other Licenses	60
9. Unenforceable Provisions	61
10. Governing Law	61
11. Waiver	61

List of Figures

1	SmartNode SN4170 (Front)	15
2	SN4170 Rear Panels	16
3	SmartNode SN4170 rear panel ports (SN4170/2ETH model shown)	16
4	SmartNode SN4170 front panel	18
5	Convert Legacy PBX to VoIP	20
6	Migrate from VoIP Gateway to eSBC	21
7	Power LED	26
8	Connecting the SmartNode to your Laptop PC	29
9	Connecting the SmartNode to the network	31
10	Connecting the SmartNode to your Laptop PC	32
11	Connecting the SmartNode to the network	34
12	Connecting a serial terminal	47
13	Typical Ethernet straight-through cable diagram for 10/100Base-T	48
14	Typical Ethernet straight-through cable diagram for 1000Base-T	48
15	PSTN NT Cabling	49
16	Crossover cable pinout	49
17	EIA-561 (RJ-45 8-pin) port	51
18	Reset button	56
19	Reset button periods (in seconds) for performing actions	56

List of Tables

1	General conventions	12
2	Rear panel ports	16
3	SmartNode SN4170 LED Definitions	18
4	Sample site log entries	23
5	Factory Default IP Address and Network Mask Configuration	29
6	Factory Default IP Address and Network Mask Configuration	32
7	10/100 Base-T RJ-45 socket	51
8	1000Base-T RJ-45 Socket	52
9	Port 0/0	52
10	Results from pressing the Reset button	56
11	Using the Reset button to switch to a backup image or erase flash memory	57

About this guide

This guide describes the SmartNode SN4170 hardware, installation and basic configuration. For detailed software configuration information refer to the *Trinity Command Line Reference Guide* and the available *Web Wizard*.

Audience

This guide is intended for the following users:

- Operators
- Installers
- Maintenance technicians

Structure

This guide contains the following chapters and appendices:

- [Chapter 1](#) on page 14 provides information about gateway features and capabilities
- [Chapter 2](#) on page 19 contains an overview describing gateway operation and applications
- [Chapter 3](#) on page 22 provides quick start hardware installation procedures
- [Chapter 4](#) on page 27 provides quick-start procedures for configuring the SmartNode gateway
- [Chapter 5](#) on page 36 contains information on contacting Patton technical support for assistance
- [Appendix A](#) on page 39 contains compliance and regulatory information for the gateway
- [Appendix B](#) on page 42 contains specifications for the gateways
- [Appendix C](#) on page 46 provides cable recommendations
- [Appendix D](#) on page 50 describes the gateway's ports and pin-outs
- [Appendix E](#) on page 53 lists the factory configuration settings for SmartNode SN4170
- [Appendix F](#) on page 55 describes the *Reset* button functions
- [Appendix G](#) on page 58 provides license information that describes acceptable usage of the software provided with the SmartNode SN4170

For best results, read the contents of this guide *before* you install the VoIP Gateway.

Precautions

Notes, cautions, and warnings, which have the following meanings, are used throughout this guide to help you become aware of potential problems. *Warnings* are intended to prevent safety hazards that could result in personal injury. *Cautions* refer to potential property damage or impaired functioning.

Note Calls attention to important information.



The shock hazard symbol and **WARNING** heading indicate a potential electric shock hazard. Strictly follow the warning instructions to avoid injury caused by electric shock.



The alert symbol and **WARNING** heading indicate a potential safety hazard. Strictly follow the warning instructions to avoid personal injury.



The shock hazard symbol and **CAUTION** heading indicate a potential electric shock hazard. Strictly follow the instructions to avoid property damage caused by electric shock.



The alert symbol and **CAUTION** heading indicate a potential hazard. Strictly follow the instructions to avoid property damage.

Safety when working with electricity



The SmartNode device contains no user serviceable parts, and is not to be opened by the user. The equipment shall be returned to Patton Electronics for repairs or repaired by qualified service personnel.



Mains Voltage: In systems without a power switch, line voltages are present in the power supply when the power cord is connected. The mains outlet used to power the SmartNode device shall be within 10 feet (3 meters) of the device, be easily accessible, and protected by a circuit breaker.



For AC powered units, ensure that the power cable used meets all applicable standards for the country in which it is to be installed, and that it is connected to a wall outlet which has earth ground.



For units with an external power adapter, the adapter shall be a listed Limited Power Source.



Hazardous network voltages are present in WAN ports regardless of whether power to the SmartNode is ON or OFF. To avoid electric shock, use caution when near WAN ports. When detaching the cables, detach the end away from the SmartNode first.



Before handling the device, disconnect the telephone network cables to avoid contact with telephone line voltages. When detaching the cables, detach the end away from the SmartNode device first.



Do not work on the system or connect or disconnect cables during periods of lightning activity.

Deutsch

Warnhinweise:



Dieses Gerät ist NICHT für den Anschluss an das Telefonnetz (PSTN) bestimmt und auch NICHT dafür zugelassen. Es ist nur für den Anschluss an Endgeräte beim Kunden vorgesehen.



- Das Gerät enthält keine austauschbaren Komponenten und ist vom Benutzer nicht zu öffnen. Bei Systemen ohne Netzschalter und ohne externes Netzteil liegt Netzspannung im Gerät an, wenn das Netzkabel angeschlossen ist.
- Bei Geräten mit externem Netzteil muss das Netzteil die Anforderungen an eine zugelassene Stromquelle mit begrenzter Leistung erfüllen. Die Steckdose, die für die Stromversorgung des Gerätes verwendet wird, sollte höchstens 3 Meter vom Gerät entfernt und leicht zugänglich sein sowie durch einen den örtlichen regulatorischen Anforderungen entsprechenden Schutzschalter abgesichert sein.
- Für mit Wechselstrom betriebene Geräte muss sichergestellt sein, dass das verwendete Netzkabel alle gültigen Normen des Landes erfüllt, in dem es eingesetzt werden soll.
- Für mit Wechselstrom betriebene Geräte, die 3-polige Netzstecker haben (L1, L2 u. GND oder Phase, Neutralleiter u. Schutzleiter), muss die Steckdose geerdet sein.
- Für mit Gleichstrom betriebene Geräte muss sichergestellt sein, dass die Verbindungskabel für Spannung, Strom, erwartete Temperatur, Entflammbarkeit und mechanische Wartbarkeit geeignet sind.
- WAN-, LAN- u. PSTN-Ports (Anschlüsse) können unter gefährlicher Spannung stehen, unabhängig davon, ob das Gerät ein- oder ausgeschaltet ist. PSTN bezieht sich auf Schnittstellen wie Telefon, FXS, FXO, DSL, xDSL, T1, E1, ISDN, Voice, usw. Diese sind als „gefährliche Netzwerkspannungen“ bekannt. Um einen elektrischen Schlag zu vermeiden, muss in der Nähe dieser Anschlüsse mit Vorsicht gearbeitet werden. Werden Kabel von diesen Anschlüssen getrennt, zuerst das Kabel am anderen Ende herausziehen.
- Während eines Gewitters darf nicht am Gerät gearbeitet werden und es dürfen keine Kabel angeschlossen oder vom Netz getrennt werden.



In Übereinstimmung mit den Anforderungen der Richtlinie 2002/96/EG über Elektro- und Elektronik-Altgeräte (WEEE) muss sichergestellt sein, dass Altgeräte von anderem Abfall und Schrott getrennt werden und dem Sammel- und Verwertungssystem für Elektro- und Elektronik-Altgeräte in Ihrem Land zum Recycling zugeführt werden.

General observations



Do not stack multiple SmartNode devices directly on top of one another, and do not place items on top of the device. If you will be installing equipment above the SmartNode device, leave at least 2 inches (5 cm) of clearance between the devices.

Furthermore, leave at least 2 inches (5 cm) to the left, right, front, and rear of the SmartNode device for proper ventilation.



In accordance with the requirements of council directive 2002/96/EC on Waste of Electrical and Electronic Equipment (WEEE), ensure that at end-of-life you separate this product from other waste and scrap and deliver to the WEEE collection system in your country for recycling.

- Clean the case with a soft slightly moist anti-static cloth
- Place the unit on a flat surface and ensure free air circulation
- Avoid exposing the unit to direct sunlight and other heat sources
- Protect the unit from moisture, vapors, and aggressive liquids

Typographical conventions used in this document

Procedures described in this manual use the following text conventions:

Table 1. General conventions

Convention	Meaning
Garamond blue type	Indicates a cross-reference hyperlink that points to a figure, graphic, table, or section heading. Clicking on the hyperlink jumps you to the reference. When you have finished reviewing the reference, click on the Go to Previous View button  in the Adobe® Acrobat® Reader toolbar to return to your starting point.
Helvetica bold type	Commands and keywords are in boldface font.
Helvetica bold-italic type	Parts of commands, which are related to elements already named by the user, are in boldface italic font.
Italicized Helvetica type	Variables for which you supply values are in <i>italic</i> font
Helvetica type	Indicates the names of fields or windows.
Garamond bold type	Indicates the names of command buttons that execute an action.
< >	Angle brackets indicate function and keyboard keys, such as <SHIFT>, <CTRL>, <C>, and so on.
[]	Elements in square brackets are optional.
{ a b c }	Alternative but required keywords are grouped in braces ({ }) and are separated by vertical bars ()
blue screen	Information you enter is in blue screen font.

Table 1. General conventions (Continued)

Convention	Meaning
screen	Terminal sessions and information the system displays are in screen font.
<i>node</i>	The leading IP address or nodename of a SmartNode is substituted with <i>node</i> in bold-face italic font.
SN	The leading SN on a command line represents the nodename of the SmartNode
#	An hash sign at the beginning of a line indicates a comment line.

Chapter 1 **General Information**

Chapter contents

- SmartNode 4170 Overview15
- SmartNode 4170 Rear Panel15
 - Ports descriptions16
 - Rest button functions17
- SmartNode 4170 Front Panel18

SmartNode SN4170 Overview

The SmartNode SN4170 is the next-generation ISDN T1/E1 model of the proven market-leading SmartNode VoIP product family. It fits perfectly the requirements of small and medium-sized enterprises looking for cost-effective ways to bridge PBX systems on multiple sites or connect them to a public Internet telephony service.



Figure 1. SmartNode SN4170 (Front)

The SmartNode SN4170 consists of several models: see the complete SKU list on the corresponding product page on www.patton.com.

All SN4170 models come equipped with one or two 10/100/1000 Base-T Ethernet port and 1PRI (E1/T1) port.

The SmartNode SN4170 E1/T1 VoIP Gateway performs the following major functions:

- 15 up to 30 channels of Voice over IP and local voice switching via one ISDN PRI E1/T1 port. The port can be switched between NT and TE per software. However the port pin-out always stays the same.
- Standard compliant VoIP in accordance with SIPv2 protocol.
- Supports from 15 up to 200* SIP to SIP calls (additional cost SNSW-1B)
- SIP registrar, SIP TLS, and SRTP are optionally available on all SN4170 models at additional charge.
- USB 2.0 host port for 3G/4G modem support, which can be used for Survivability applications as a data backup link.
- One 10/100/1000 Ethernet port (/2ETH models have two)

Note A list of supported USB Models can be found in the release notes and in the Trinity Command Line Reference Guide.

*Supported under ideal conditions. Transcoding, debugging, and/or IP routing reduce processing capacity.

SmartNode SN4170 Rear Panel

The SmartNode SN4170 is a compact VoIP Gateway that supports 15 up to 30 VoIP or Fax calls, by using either G.711, G.722, T.38 or any other codec as indicated under Voice Processing in Appendix B, “Specifications” on page 42. The SmartNode SN4170 rear panel (see [figure 2](#) on page 16) is described in section “Ports descriptions” on page 16.



Figure 2. SN4170 Rear Panels

Ports descriptions

The SmartNode SN4170 rear panel ports (see figure 3) are described in table 2.

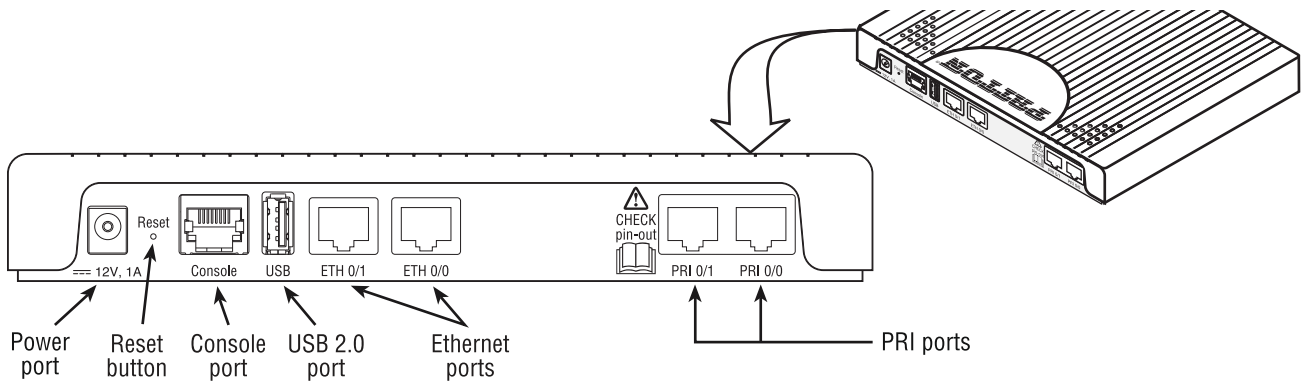

Figure 3. SmartNode SN4170 rear panel ports (SN4170/2ETH model shown)

Table 2. Rear panel ports

Port	Description
ETH 0/0 - ETH 0/1	Auto-MDX Fast-/Gigabit-Ethernet port, RJ45 (see figure 2), connects the unit to an Ethernet WAN device (for example, a cable modem, DSL modem, or fiber modem) or it connects to the Ethernet switch of a company LAN. Note IP Routing is disabled on SN4170/2ETH models. See Software license options to enable it.
USB 2.0	USB 2.0 host port (see figure 2) to connect a USB 3G/4G Cellular Modem. A list of supported USB Models can be found in the release notes and in the Trinity Command Line Reference Guide

Table 2. Rear panel ports (Continued)

Port	Description
PRI 0/0 - PRI 0/1	<p>RJ-45 connector providing E1 or T1 PRI interface, meeting all requirements of ITU-T recommendations for G.703. Use a shielded E1 or T1 interface cable for 120 Ohm balanced connections to connect the SmartNode with an NT or TE.</p> <p>Note Refer to Appendix C on page 46 for cabling and Appendix D on page 50 for pin-outs</p>
Console	<p>Used for service and maintenance, the console port (see figure 2 on page 16) an RS-232 RJ-45 connector, connects the product to a serial terminal such as a PC or ASCII Terminal (also called a dumb terminal).</p> <p>Configuration settings:</p> <ul style="list-style-type: none"> • 19200 bps • 8 bits, no parity • 1 stop bit • flow control off
12V DC, 1A	Electricity supply socket. (see figure 2 on page 16)
Reset	The reset button has several functions, as described in appendix F, “ Reset Button Functions ” on page 55.

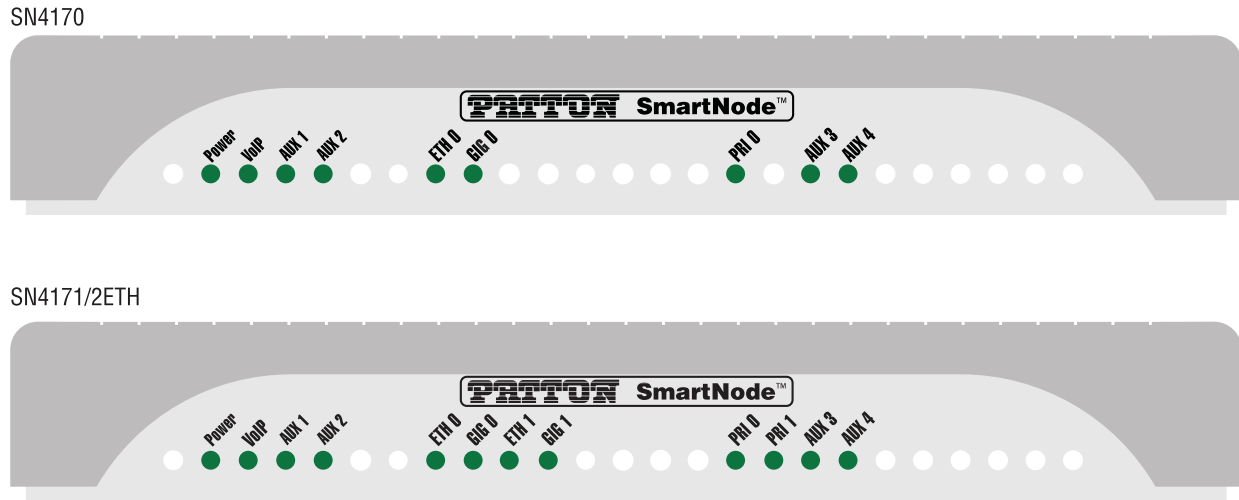

Figure 4. SmartNode SN4170 front panel

SmartNode SN4170 Front Panel

Figure 4 shows SmartNode SN4170 LEDs, the LED definitions are listed in [table 3](#).

Table 3. SmartNode SN4170 LED Definitions

LED	Description
	Note If an error occurs, all LEDs will flash for more than 5 seconds before the device reboots
Power	When lit, indicates power is applied. Blinks fast during bootloader phase and blinks slow during boot process of Trinity Software. Stays lit when the system is up and running.
VoIP	<ul style="list-style-type: none"> On indicates the gateway is registered to a SIP server, or, a SIP device has registered to the SN4170. Off indicates the unit is not configured or registered, or has no active direct routed VoIP connection.
AUX 1– AUX 4	<ul style="list-style-type: none"> Auxiliary LEDs for future use.
PRI 0 - PRI 1	<ul style="list-style-type: none"> On when L1 and L2 are active. Flashes when there are ongoing calls. Off when no line or PBX is connected or the port is shutdown.
ETH 0 - ETH 1	<ul style="list-style-type: none"> On when the Ethernet connection on the corresponding port has a link indication. Flashes when data is received or transmitted at the corresponding Ethernet port. <p>Note IP Routing is disabled on SN4170/2ETH models. See Software license options to enable it.</p>
GIG 0 - GIG 1	<ul style="list-style-type: none"> On when the Ethernet is connected to a 1000Mb network. Off when the Ethernet is connected to a 10Mb or 100Mb network or not connected

Chapter 2 Applications Overview

Chapter contents

- Introduction20
- Application—Convert Legacy PBX to VoIP20
 - How it works:20
- Application—Migrate from VoIP Gateway to eSBC21
 - How it works:21

Introduction

SmartNode products provide seamless network integration, continuous trouble-free operation and cost effective deployment to protect your investments for the future. Preserve investments in legacy phone equipment while taking the next steps toward unified communications with the SN4170 VoIP Gateway.

Note Detailed configuration information for SmartNode applications is available online at: <http://www.patton.com/voip-gateway/>.

Application—Convert Legacy PBX to VoIP

For an installation where there are existing routers and access modems, the SN4170 is a cost-effective solution to bring SIP-trunking service to a traditional PBX.

But also for an ISDN PSTN Line integration in to a IPPBX, the SN4170 is the perfect selection for such an application.



Figure 5. Convert Legacy PBX to VoIP

How it works:

1. Download the Wizard from <http://www.patton.com/wizard/> designed for SN4170
2. Connect your PC to SN4170 and upload the previous downloaded Wizard
3. Execute the Wizard on SN4170 and hit “save & reboot”
4. Once the SmartNode has rebooted, it is ready to use
5. Connect the SN4170 to your Ethernet Switch
6. Connect the E1/T1 cable of your Legacy PBX to the PRI port of the SN4170
7. You can now initiate and receive phone calls through a SIP trunk using the legacy PBX

Application—Migrate from VoIP Gateway to eSBC

Models containing “SN4171/2ETH” are capable of accepting a software license to achieve this additional functionality future proofing your voice network for next generation SIP services and security.

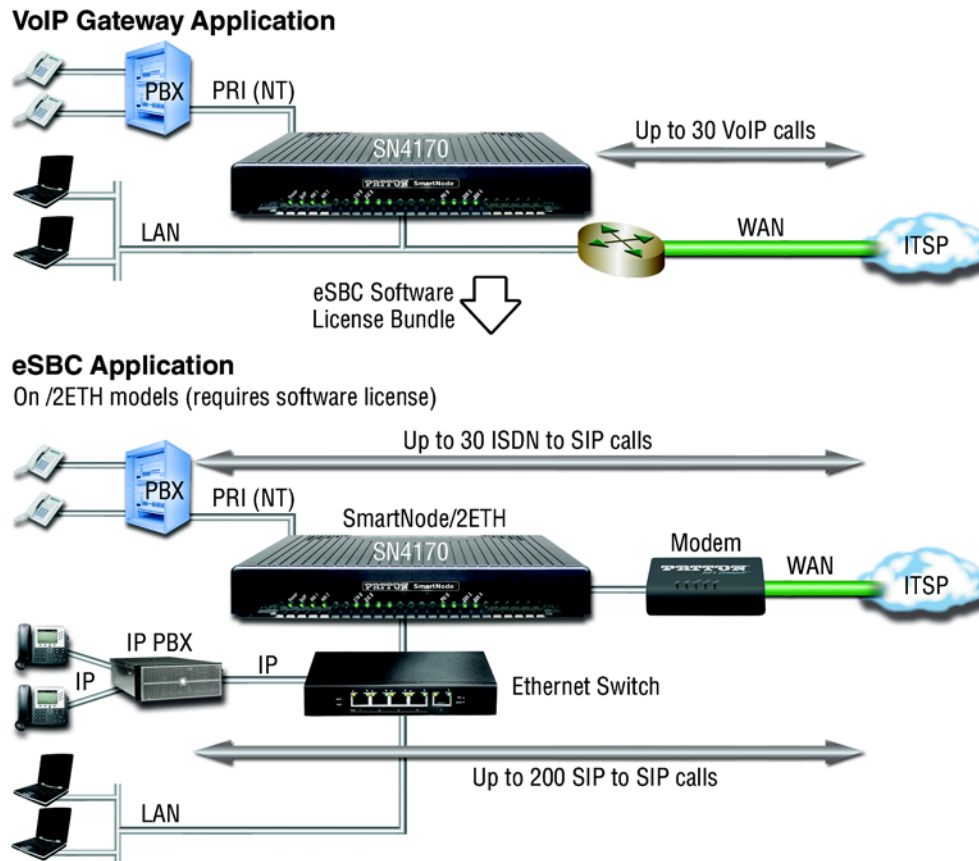

Figure 6. Migrate from VoIP Gateway to eSBC

How it works:

1. Purchase an eSBC license bundle.
2. load licenses onto your SmartNode device.
3. Enhance your config for the VoIP Gateway to become an eSBC (check for Wizards and our software configuration manual on how to do that in detail).

Chapter 3 **SmartNode Installation**

Chapter contents

Planning the Installation.....	23
Site log	23
Network information	23
Network Diagram	23
IP related information	23
Software tools	24
Power source	24
Location and mounting requirements	24
Installing the Patton SmartNode VoIP Gateway.....	24
Placing the SmartNode	24
Installing cables	25
Connecting ISDN PBX and NT to the SmartNode's ISDN PRI port	25
Connecting the 10/100/1000Base-T Ethernet cable	25
Connecting the Power Supply	26

Planning the Installation

Before installing the SmartNode device, the following tasks should be completed:

- **Create a network diagram** (see section “[Network information](#)” on page 23)
- **Gather IP related information** (see section “[IP related information](#)” on page 23 for more information)
- **Install the hardware and software needed to configure the SmartNode.** (See section “[Software tools](#)” on page 24)
- **Verify power source reliability** (see section “[Power source](#)” on page 24).

When you finish preparing for SmartNode installation, go to section “[Installing the Patton SmartNode VoIP Gateway](#)” on page 24 to install the device.

Site log

Patton recommends that you maintain a site log to record all actions relevant to the system, if you do not already keep such a log. Site log entries should include information such as listed in Table 4.

Table 4. Sample site log entries

Entry	Description
Installation	Make a copy of the installation checklist and insert it into the site log
Upgrades and maintenance	Use the site log to record ongoing maintenance and expansion history
Configuration changes	Record all changes and the reasons for them
Maintenance	Schedules, requirements, and procedures performed
Comments	Notes, and problems
Software	Changes and updates to Trinity software

Network information

Network connection considerations that you should take into account for planning are described for several types of network interfaces in the following sections.

Network Diagram

Draw a network overview diagram that displays all neighboring IP nodes, connected elements and telephony components.

IP related information

Before you can set up the basic IP connectivity for your SmartNode SN4170 you should have the following information:

- IP addresses used for the Ethernet port
- Subnet mask used for the Ethernet port

- IP addresses and/or URL of SIP servers or Internet telephony services (if used)
- Login and password for PPPoE Accesss
- Login and Password for SIP based telephony services
- IP addresses of central TFTP server used for configuration upload and download (optional)

Software tools

You will need a PC (or equivalent) with Windows Telnet or a program such as Tera Term Pro or Putty to configure the software on your SmartNode gateway.

Also you may use your WEB browser to configure the unit. The Web wizard in this case reduces time to get your unit up and running. See more details on the *Web Wizard*.

Power source

If you suspect that your AC power is not reliable, for example if room lights flicker often or there is machinery with large motors nearby, have a qualified professional test the power. Patton recommends that you include an uninterruptible power supply (UPS) in the installation to ensure that VoIP service is not impaired if the power fails.

Location and mounting requirements

The SmartNode gateway is intended to be placed on a desktop or similar sturdy, flat surface that offers easy access to cables. Allow sufficient space at the rear of the chassis for cable connections. Additionally, you should consider the need to access the unit for future upgrades and maintenance.

Installing the Patton SmartNode VoIP Gateway

SmartNode Gateway installation consists of the following:

- Placing the device at the desired installation location (see section “[Placing the SmartNode](#)” on page 24)
- Installing the interface and power cables (see section “[Installing cables](#)” on page 25)

When you finish installing the SmartNode, go to Chapter 4, “[Initial Configuration](#)” on page 27.

Placing the SmartNode

Place the SmartNode on a desktop or similar sturdy, flat surface that offers easy access to the cables. The SmartNode should be installed in a dry environment with sufficient space to allow air circulation for cooling. In order to prevent overheating and damaging the unit, proper ventilation is required when stacking the device.



To prevent overheating and damaging the unit, proper ventilation is required when placing the device; leave at least 2 inches (5 cm) to the left, right, front, and rear of the SmartNode device.

The device should be installed in a dry environment with sufficient space to allow air circulation for cooling. Do not stack multiple SmartNode devices directly on top of one another, and do not place items on top of the device. If you will be installing equipment above the SmartNode device, leave at least 2 inches (5 cm) of clearance between the devices.

Installing cables



Do not work on the system or connect or disconnect cables during periods of lightning activity.



The Interconnecting cables shall be acceptable for external use and shall be rated for the proper application with respect to voltage, current, anticipated temperature, flammability, and mechanical serviceability.

Connect the cables in the following order:

1. Connect the ISDN PBX and NT to the PRI port (see section “[Connecting ISDN PBX and NT to the SmartNode’s ISDN PRI port](#)”)
2. Connect the 10/100/1000Base-T Ethernet Port (see section “[Connecting the 10/100/1000Base-T Ethernet cable](#)”)
3. Connect the power mains cable (see section “[Connecting the Power Supply](#)” on page 26)

Connecting ISDN PBX and NT to the SmartNode’s ISDN PRI port

The SmartNode comes with one ISDN PRI (E1/T1) port located on the rear panel (see figure 2 on page 16). The port can be connected to the PSTN (ISDN NT) or to a PBX (ISDN TE). Please check the cabling and port pinout first, before connecting the SmartNode ISDN port. See Appendix C, “[Cabling](#)” on page 46



For the ISDN connection to a carrier Network, it shall be connected to a Network Termination Device and not connected directly to an outside POTS line.

For details on the PRI port pinout and ISDN cables, refer to [Appendix C, “Cabling”](#) on page 46 and [Appendix D, “Port pin-outs”](#) on page 50.

Connecting the 10/100/1000Base-T Ethernet cable

The SmartNode SN4170 has automatic MDX (auto-cross-over) detection and configuration on the Ethernet port. The port can be connected to a host or hub/switch with a straight-through wired cable.

- Connect to the subscriber port of the broadband access modem (DSL, cable, WLL) to ETH 0/0.

For details on the Ethernet port pinout and cables, refer to [Appendix C, “Cabling”](#) on page 46 and [Appendix D, “Port pin-outs”](#) on page 50.

Connecting the Power Supply

Do the following to connect the main power to the Model SN4170:

Note *Do not connect the power cord to the AC Mains at this time.*

1. Insert the female end of the AC power supply cable to the mains port (see [figure 2](#) on page 16).



There are no user-serviceable parts in the power supply section of the model SN4170. Contact Patton Electronics Technical Support at support@patton.com for more information

2. Verify that the AC power cord included with your device is compatible with local standards. If it is not, refer to “[Contacting Patton for Assistance](#)” on page 36 to find out how to replace it with a compatible power cord.
3. Connect the male end of the power cord to an appropriate power outlet.

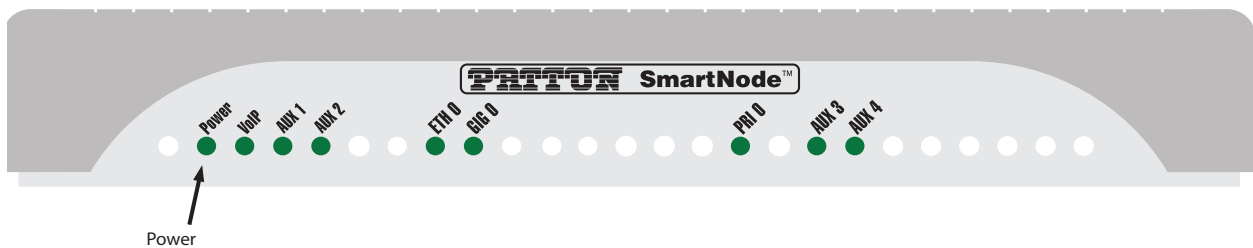

Figure 7. Power LED

4. Verify that the green *Power* LED is lit (see [figure 7](#)). Blinks fast during bootloader phase and blinks slow during boot process of Trinity Software. Becomes solid when the system is up and running.

Congratulations, you have finished installing the SmartNode E1/T1 PRI VoIP Gateway! Now go to [Chapter 4](#), “[Initial Configuration](#)” on page 27.

Chapter 4 Initial Configuration

Chapter contents

Introduction	28
Connecting the SmartNode 4171 to Your Laptop PC	28
Configure the Desired IP Address	29
Factory-default IP Settings	29
Login	29
Changing the WAN IP address	30
Connecting the SmartNode to the Network	30
Connecting SN4171/2ETH models to your PC	31
Configure the Desired IP Address	32
Factory-default IP Settings	32
Login	32
Changing the WAN IP address	33
Connecting the SmartNode to the Network	33
Loading the Configuration (optional)	34
Additional Information	35

Introduction

This chapter leads you through the basic steps to set up a new SmartNode and to download a configuration. Setting up a new SmartNode consists of the following main steps:

Note If you haven't already installed the SmartNode, refer to Chapter 3, "SmartNode Installation" on page 22.

- Connecting the SmartNode to your laptop PC
- Configuring the desired IP address (see page 29)
- Connecting the SmartNode to the network (see page 30)
- Loading the configuration (optional) (see page 34)

For 2ETH models, set up consists of the following:

- Connecting SN4171/2ETH models to the network (see page 31)
- Configuring the desired IP address (see page 32)
- Changing the WAN IP address (see page 33)
- Connecting the SmartNode to the network (see page 33)
- Loading the configuration (optional) (see page 34)

Connecting the SmartNode 4171 to Your Laptop PC

First, the SmartNode must be connected to the main power supply with the power cable. Wait until the Power LED stops blinking and stays lit constantly. Now the SmartNode is ready.



CAUTION

The interconnecting cables shall be acceptable for external use and shall be rated for the proper application with respect to voltage, current, anticipated temperature, flammability, and mechanical serviceability.



CAUTION

For the ISDN connection to a carrier network, it shall be connected to a network termination device and not connected directly to an outside POTS line.

The SmartNode SN4170 is equipped with an Auto-MDX Ethernet port, so you can use straight-through cables for host or hub/switch connections (see figure 8).

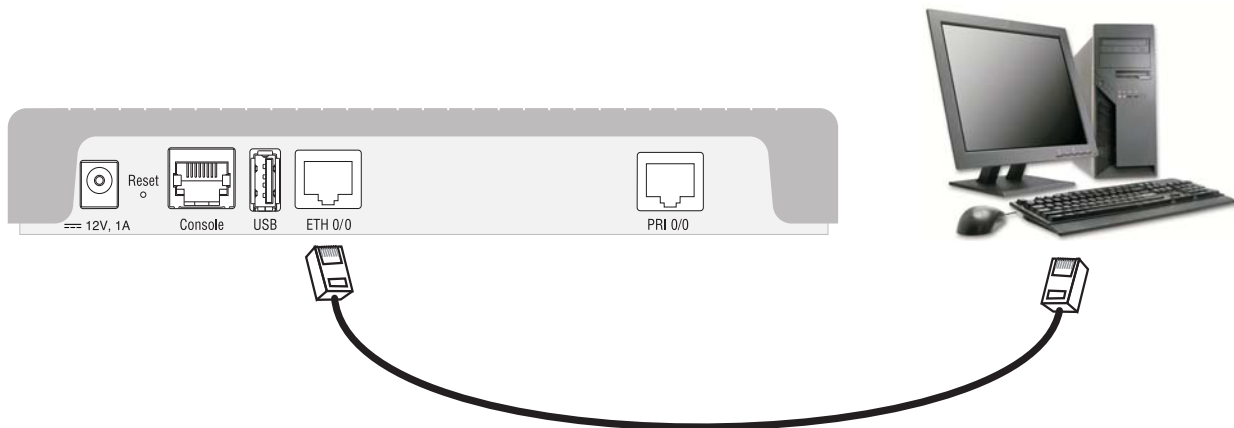

Figure 8. Connecting the SmartNode to your Laptop PC

The SmartNode comes with a built-in DHCP client and a fixed IP address to simplify configuration. The SmartNode will receive an IP address from the DHCP server in the network or it can be directly accessed using the static IP address.

Configure the Desired IP Address

Factory-default IP Settings

The factory default configuration for the Ethernet interface IP addresses and network masks are listed in Table 5. The Ethernet interface is activated upon power-up. The WAN interface uses DHCP client to automatically assign the IP address and network mask.

Table 5. Factory Default IP Address and Network Mask Configuration

	IP Address	Network Mask
WAN Interface Ethernet 0 0(ETH 0/0)	DHCP	DHCP
Static IP Address	192.168.1.1	255.255.255.0

If these addresses match with those of your network, go to section “[Connecting the SmartNode to the Network](#)” on page 30. Otherwise, refer to the following sections to change the addresses and network masks.

Login

To access the SmartNode, start the Telnet application. Type either the default IP address into the address field of the Telnet application:

192.168.1.1

OR run the SmartNode Discovery Tool, to access the SmartNode.

Accessing your SmartNode via a Telnet session displays the login screen. Type the factory default login: *admin* and leave the password empty. Press the Enter key after the password prompt.

```
login:admin
password: <Enter>
192.168.1.1>
```

After you have successfully logged in you are in the operator execution mode, indicated by > as command line prompt. With the commands *enable* and *configure* you enter the configuration mode.

```
192.168.1.1>enable
192.168.1.1#configure
192.168.1.1(cfg)#
```

Changing the WAN IP address

Select the context IP mode to configure an IP interface.

```
192.168.1.1 (cfg) #context ip ROUTER
192.168.1.1 (ctx-ip) [ROUTER] #
```

Now you can set your IP address and network mask for the interface *ETH 0/0* (WAN). Within this example a network 172.16.1.0/24 address is assumed. The IP address in this example is set to 172.16.1.99 (you should set the IP address given to you by your network provider).

```
192.168.1.1(ctx-ip)[Router]#interface WAN
192.168.1.1(if-ip)[WAN]#no ipaddress DHCP
192.168.1.1(if-ip)[WAN]#ipaddress WAN 172.16.1.99/24
2002-10-28T00:09:40 : LOGININFO : Link down on interface WAN.
2002-10-29T00:09:40 : LOGININFO: Link up on interface WAN.
172.16.1.99(if-ip)[WAN]#
```

Copy this modified configuration to your new start-up configuration. This will store your changes in non-volatile memory. Upon the next start-up the system will initialize itself using the modified configuration.

Note The modified configuration is applied immediately. It is not necessary to reboot the device when changing any configuration parameter.

```
172.16.1.99(if-ip) [WAN]#copy running-config startup-config
172.16.1.99(if-ip) [WAN]
```

The SmartNode can now be connected to your network.

Connecting the SmartNode to the Network

In general, the SmartNode will connect to the network via the *WAN (ETH 0/0)* port. The SmartNode SN4170 is equipped with an Auto-MDX Ethernet port, so you can use straight through or crossover cables for host or hub/switch connections. (see [figure 9](#) on page 31).



The interconnecting cables shall be acceptable for external use and shall be rated for the proper application with respect to voltage, current, anticipated temperature, flammability, and mechanical serviceability.



For the ISDN connection to a carrier network, it shall be connected to a network termination device and not connected directly to an outside POTS line.

You can check the connection with the ping command from the SmartNode to another host on the network.

```
172.16.1.99(if-ip)[WAN]#ping <IP Address of the host>
```

Note If the WAN address is **not** set to DHCP, to ping a device outside your local LAN you must first configure the default gateway. (For information on configuring the default gateway, refer to section “Set IP addresses” in the Trinity Command Line Reference Guide.)

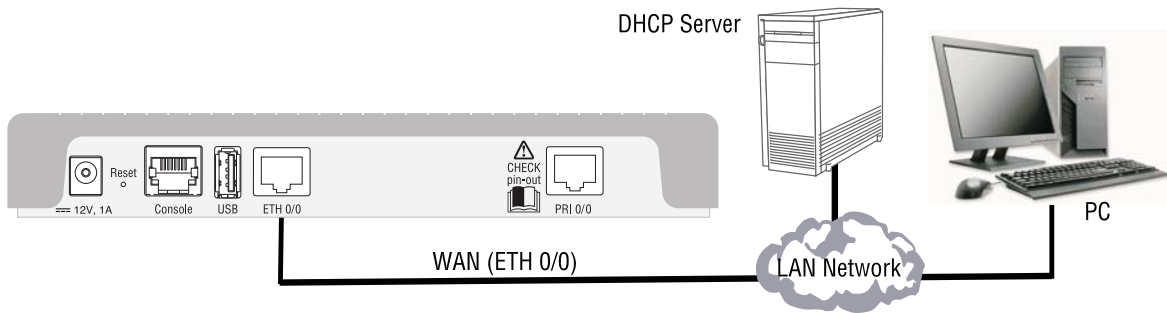

Figure 9. Connecting the SmartNode to the network

Connecting SN4171/2ETH models to your PC

First, the SmartNode must be connected to the main power supply with the power cable. Wait until the Power LED stops blinking and stays lit constantly. Now the SmartNode is ready.



The interconnecting cables shall be acceptable for external use and shall be rated for the proper application with respect to voltage, current, anticipated temperature, flammability, and mechanical serviceability.



For the ISDN connection to a carrier network, it shall be connected to a network termination device and not connected directly to an outside POTS line.

The SmartNode device is equipped with Auto-MDX Ethernet ports, so you can use straight-through cables for host or hub/switch connections (see figure 8).

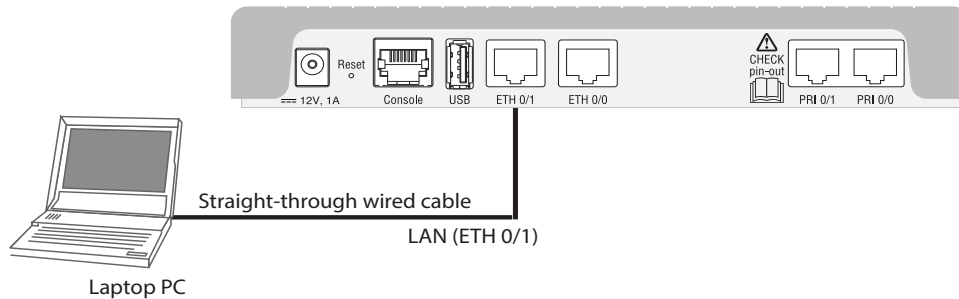

Figure 10. Connecting the SmartNode to your Laptop PC

The SmartNode comes with a built-in DHCP server to simplify configuration. Therefore, to automatically configure the PC for IP connectivity to the SmartNode, the Laptop PC must be configured for DHCP. The SmartNode will provide the PC with an IP address. You can check the connection to the SmartNode by executing the ping command from the PC command window as follows:

```
ping 192.168.1.1
```

Configure the Desired IP Address

Factory-default IP Settings

The factory default configuration for the Ethernet interface IP addresses and network masks are listed in [table 6](#). Both Ethernet interfaces are activated upon power-up. LAN interface *ETH 0/1* (*LAN*) provides a default DHCP server, the WAN interface uses DHCP client to automatically assign the IP address and network mask.

Table 6. Factory Default IP Address and Network Mask Configuration

	IP Address	Network Mask
WAN Interface Ethernet 0 (ETH 0/0)	DHCP	DHCP
LAN Interface Ethernet 1 (ETH 0/1)	192.168.1.1	255.255.255.0
DHCP Address Range	192.168.1.10–192.168.1.99	255.255.255.0

If these addresses match with those of your network, go to section “[Connecting the SmartNode to the Network](#)” on page 30. Otherwise, refer to the following sections to change the addresses and network masks.

Login

To access the SmartNode, start the Telnet application. Type either the host name

```
smartnode.local
```

or the default IP address into the address field of the Telnet application:

```
192.168.1.1
```

Accessing your SmartNode via a Telnet session displays the login screen. Type the factory default login: *admin* and leave the password empty. Press the Enter key after the password prompt.

```
login:admin
password: <Enter>
192.168.1.1>
```

After you have successfully logged in you are in the operator execution mode, indicated by > as command line prompt. With the commands *enable* and *configure* you enter the configuration mode.

```
192.168.1.1>enable
192.168.1.1#configure
192.168.1.1(cfg)#
```

Changing the WAN IP address

Select the context IP mode to configure an IP interface.

```
192.168.1.1 (cfg) #context ip ROUTER
192.168.1.1 (ctx-ip) [ROUTER] #
```

Now you can set your IP address and network mask for the interface *ETH 0/0 (WAN)*. Within this example a network 172.16.1.0/24 address is assumed. The IP address in this example is set to *172.16.1.99* (you should set the IP address given to you by your network provider).

```
192.168.1.1(ctx-ip)[Router]#interface WAN
192.168.1.1(if-ip)[WAN]#no ipaddress DHCP
192.168.1.1(if-ip)[WAN]#ipaddress WAN 172.16.1.99/24
2002-10-28T00:09:40 : LOGININFO : Link down on interface WAN.
2002-10-29T00:09:40 : LOGININFO: Link up on interface WAN.
172.16.1.99(if-ip)[WAN]#
```

Copy this modified configuration to you new start-up configuration. This will store your changes in non-volatile memory. Upon the next start-up the system will initialize itself using the modified configuration.

Note The modified configuration is applied immediately. It is not necessary to reboot the device when changing any configuration parameter.

```
172.16.1.99(if-ip) [WAN]#copy running-config startup-config
172.16.1.99(if-ip) [WAN]
```

The SmartNode can now be connected to your network.

Connecting the SmartNode to the Network

In general, the SmartNode will connect to the network via the WAN (ETH 0/0) port and PC hosts, IPPBX, IP phones, etc. on LAN (ETH 0/1) port. The SmartNode 4170 is equipped with Auto-MDX Ethernet ports, so you can use straight-through or crossover cables for host or hub/switch connections. (See [figure 11](#) on page 34).

Note The SN4171 does not have routing and NAT functions enabled by default. They can be enabled by purchasing the corresponding software licenses.



The interconnecting cables shall be acceptable for external use and shall be rated for the proper application with respect to voltage, current, anticipated temperature, flammability, and mechanical serviceability.



For the ISDN connection to a carrier network, it shall be connected to a network termination device and not connected directly to an outside POTS line.

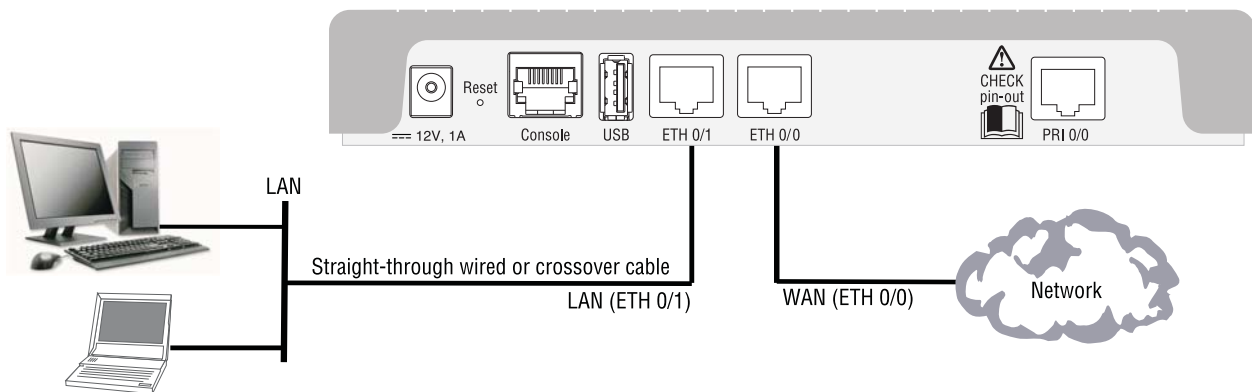

Figure 11. Connecting the SmartNode to the network

You can check the connection with the ping command from the SmartNode to another host on the network.

```
172.16.1.99(if-ip)[WAN]#ping <IP Address of the host>
```

Note If the WAN address is *not* set to DHCP, to ping a device outside your local LAN you must first configure the default gateway. (For information on configuring the default gateway, refer to section “Set IP addresses” in the Trinity Release 3.5.x– Command Line Reference Guide.)

Note Connecting both Ethernet ports to the same switch will only work if the switch has separate ARP tables for each connection.

Note IP Routing is disabled on SN4171 models. See Software license options to enable it.

Loading the Configuration (optional)

The Patton Community provides several Web Wizards to help with setting up your SmartNode configuration.

<http://www.patton.com/wizard>

Patton also provides a collection of configuration templates on the support page at:

<http://www.patton.com/support/kb.asp> —one of which may be similar enough to your application that you

can use it to speed up configuring the SmartNode. Simply download the configuration note that matches your application to your PC. Adapt the configuration as described in the configuration note to your network (remember to modify the IP address) and copy the modified configuration to a TFTP server. The SmartNode can now load its configuration from this server.

Note If your application is unique and not covered by any of Patton's configuration templates, you can manually configure the SmartNode instead of loading a configuration file template. In that case, refer to the SmartNode Series Trinity Command Line Reference Guide for information on configuring the SmartNode device.

In this example we assume the TFTP server on the host with the IP address 172.16.1.11 and the configuration named *SN.cfg* in the root directory of the TFTP server.

```
172.16.1.99(if-ip)[WAN]#copy tftp://172.16.1.11/sn.cfg startup-config
172.16.1.99(if-ip)[WAN]#
```

After the SmartNode has been rebooted the new startup configuration will be activated.

```
172.16.1.99(if-ip)[WAN]#reload
Press 'yes' to restart, 'no' to cancel :yes
The system is going down NOW
```

Additional Information

For detailed information about configuring and operating guidance, set up procedures, and troubleshooting, refer to the Trinity Command Line Reference Guide available online at www.patton.com/manuals.

Chapter 5 **Contacting Patton for Assistance**

Chapter contents

- Introduction37
- Contact information37
 - Contacting Patton Technical Services for Free Support37
- Warranty Service and Returned Merchandise Authorizations (RMAs)37
 - Warranty coverage37
 - Out-of-warranty service38
 - Returns for credit38
 - Return for credit policy38
 - RMA numbers38
 - Shipping instructions38

Introduction

This chapter contains the following information:

- “[Contact information](#)”—describes how to contact Patton technical support for assistance.
- “[Warranty Service and Returned Merchandise Authorizations \(RMAs\)](#)”—contains information about the warranty and obtaining a return merchandise authorization (RMA).

Contact information

Patton Electronics offers a wide array of free technical services. If you have questions about any of our other products we recommend you begin your search for answers by using our technical knowledge base. Here, we have gathered together many of the more commonly asked questions and compiled them into a searchable database to help you quickly solve your problems.

Contacting Patton Technical Services for Free Support

REGION	North America	Western Europe	Central & Eastern Europe	Middle East North Africa
Location	Maryland, USA	Bern, Switzerland	Budapest, Hungary	Beirut, Lebanon
Time Zone	EST/EDT UTC/GMT - 4/5 hours	CET/CEDT UTC/GMT + 1/2 hours	CET/CEDT UTC/GMT + 1/2 hours	EET/EEDT UTC/GMT + 2/3 hours
Business Hours	Monday-Friday 8:00am to 5:00pm	Monday-Friday 09:00 to 12:00 13:30 to 17:30	Monday-Friday 8:30 to 17:00	Monday-Friday 8:00am to 5pm
Email	support@patton.com	support@patton.com	support@patton.com	support@patton.com
Phone	+ 1 301 975 1007	+41 31 985 25 55	+36 439 3835	+96 1 359 1277
Fax	+1 301 869 9293	+41 31 985 2526		

Warranty Service and Returned Merchandise Authorizations (RMAs)

Patton Electronics is an ISO-9001 certified manufacturer and our products are carefully tested before shipment. All of our products are backed by a comprehensive warranty program.

Note If you purchased your equipment from a Patton Electronics reseller, ask your reseller how you should proceed with warranty service. It is often more convenient for you to work with your local reseller to obtain a replacement. Patton services our products no matter how you acquired them.

Warranty coverage

Our products are under warranty to be free from defects, and we will, at our option, repair or replace the product should it fail within one year from the first date of shipment. Our warranty is limited to defects in workmanship or materials, and does not cover customer damage, lightning or power surge damage, abuse, or unauthorized modification.

Out-of-warranty service

Patton services what we sell, no matter how you acquired it, including malfunctioning products that are no longer under warranty. Our products have a flat fee for repairs. Units damaged by lightning or other catastrophes may require replacement.

Returns for credit

Customer satisfaction is important to us, therefore any product may be returned with authorization within 30 days from the shipment date for a full credit of the purchase price. If you have ordered the wrong equipment or you are dissatisfied in any way, please contact us to request an RMA number to accept your return. Patton is not responsible for equipment returned without a Return Authorization.

Return for credit policy

- Less than 30 days: No Charge. Your credit will be issued upon receipt and inspection of the equipment.
- 30 to 60 days: We will add a 20% restocking charge (crediting your account with 80% of the purchase price).
- Over 60 days: Products will be accepted for repairs only.

RMA numbers

RMA numbers are required for all product returns. You can obtain an RMA by doing one of the following:

- Completing a request on the RMA Request page in the *Support* section at **www.patton.com**
- By calling **+1 (301) 975-1007** and speaking to a Technical Support Engineer
- By sending an e-mail to **returns@patton.com**

All returned units must have the RMA number clearly visible on the outside of the shipping container. Please use the original packing material that the device came in or pack the unit securely to avoid damage during shipping.

Shipping instructions

The RMA number should be clearly visible on the address label. Our shipping address is as follows:

Patton Electronics Company

RMA#: xxxx

7622 Rickenbacker Dr.

Gaithersburg, MD 20879-4773 USA

Patton will ship the equipment back to you in the same manner you ship it to us. Patton will pay the return shipping costs.

Appendix A **Compliance Information**

Chapter contents

- Compliance40
 - EMC40
 - Safety40
- Radio and TV interference40
- CE Declaration of Conformity40
- Authorized European Representative40
- ISDN Compliance41

Compliance

EMC

- FCC Part 15, Class A
- EN55022, Class A
- EN55024

Safety

- UL60950-1/CSA C22.2 No. 60950-1
- IEC/EN 60950-1, 2nd edition
- AS/NZS 60950-1

Radio and TV interference

The SmartNode gateway generates and uses radio frequency energy, and if not installed and used properly—that is, in strict accordance with the manufacturer's instructions—may cause interference to radio and television reception. The SmartNode gateway has been tested and found to comply with the limits for a Class A computing device in accordance with specifications in Subpart B of Part 15 of FCC rules, which are designed to provide reasonable protection from such interference in a commercial installation. However, there is no guarantee that interference will not occur in a particular installation. If the SmartNode gateway does cause interference to radio or television reception, which can be determined by disconnecting the unit, the user is encouraged to try to correct the interference by one or more of the following measures: moving the computing equipment away from the receiver, re-orienting the receiving antenna and/or plugging the receiving equipment into a different AC outlet (such that the computing equipment and receiver are on different branches).

CE Declaration of Conformity

Patton Electronics, Inc declares that this device is in compliance with the essential requirements and other provisions of Council Directive 1999/5/EC on the approximation of the laws of the member states relating to Radio and Telecommunication Terminal Equipment and the mutual recognition of their conformity.

The safety advice in the documentation accompanying this device shall be obeyed. The conformity to the above directive is indicated by the **CE** mark on the device.

The signed Declaration of Conformity can be downloaded at www.patton.com/certifications.

Authorized European Representative

D R M Green
European Compliance Services Limited.
Oakdene House, Oak Road,
Watchfield, Swindon, Wilts SN6 8TD, UK

ISDN Compliance

The device is approved for connection to the public ISDN telecommunication network.



For the ISDN connection to a carrier network, it shall be connected to a network termination device and not connected directly to an outside POTS line.

Appendix B **Specifications**

Chapter contents

DSP.....	43
Voice Connectivity.....	43
Data Connectivity.....	43
Voice Processing (signalling dependent).....	43
Fax and modem support.....	44
Voice Signalling.....	44
Voice Routing—session gateway.....	44
IP Services.....	45
Management.....	45
System.....	45
Physical.....	45

Note Refer to the software feature matrix for the most up-to-date specifications.

DSP

Two 16 channel DSP

Voice Connectivity

1 ISDN PRI port, 4-wire

RJ45 port NT/TE configurable per port (layer 1 pin-out does not change)

Data Connectivity

Two 10/100/1000Base-TX Ethernet ports (SN4171/2ETH)

One 10/100/1000Base-TX Ethernet port (SN4171)

Full duplex, autosensing, auto-MDX

Voice Processing (signalling dependent)

15 to 30 full-duplex channels with Voice CODECS:

- G.711 A-Law/-Law (64 kbps)
- G.722 (64 kbps)
- G.726 (ADPCM 16,24,32,40 kbps)
- G.723.1 (5.3 or 6.3 kbps)
- G.729ab (8kbps)
- Transparent ISDN data

G.168 echo cancellation (128ms)

15 to 30 simultaneous low-bandwidth voice or T.38 fax calls

DTMF detection and generation

Carrier tone detection and generation

Silence suppression and comfort noise

Adaptive and configurable dejitter buffer

Configurable tones (dial, ringing, busy, etc.)

Configurable transmit packet length

RTP/RTCP (RFC 1889)

SRTP (RFC 3711)

Fax and modem support

Automatic fax and modem detection

Codec fallback for modem-bypass

T.38 Fax-Relay (Gr. 3 Fax, 9.6 k, 14.4 K)

G.711 Fax-Bypass

Voice Signalling

SIPv2, SIPv2 over TLS

SIP call transfer, redirect

Overlap or en-bloc dialing

DTMF in-band, out-of-band

Configurable progress tones

Voice Routing—session gateway

Least cost routing

Interface huntgroups

Call-Distribution groups

Number blocking

Call Routing Criteria:

- Interface
- Calling/called party number
- Time of day, day of week, date
- ISDN bearer capability
- Various other information elements (IEs) of the ISDN setup
- Wildcard and regular expression matching

Regular expression number manipulation functions:

- Replace numbers
- Add/remove digits
- Pattern matching and replacement

IP Services

IPv4 gateway; IPv6 basic functionalities
Programmable static routes and policy-routing
ICMP redirect (RFC 792); Packet fragmentation
DiffServe/ToS set or queue per header bits
Packet Policing discards excess traffic
DHCP client and server
DNS client and relay-server, DynDNS

Management

Web-based GUI; Trinity WEB Wizard
Industry standard CLI with remote Telnet and SSH access, fully documented
HTTP web management and firmware loading
TFTP configuration & firmware loading
HTTPS configuration & firmware provisioning
SNMP v3 agent (MIB II and private MIB)
Built-in diagnostic tools (trace, debug)
Secure Auto-provisioning
TR-069 config file and software image provisioning

System

Dual Core CPU Broadcom BCM53012 operating at 1GHz
Memory:

- 256 Mbytes DRAM
- 32 Mbytes Flash

Physical

Dimensions: 8.2 x 1.3H x 6.5D inch (20.8W X 3.4H x 16.5D cm)
Weight: <15.9 oz. (<450g)
Power Consumption: <10W
Operating Temperature: 32-104°F (0-40°C)
Operating humidity: up to 90%, non condensing

Appendix C **Cabling**

Chapter contents

Introduction.....	47
Serial Console.....	47
Ethernet	48
ISDN PRI (E1/T1)	49

Introduction

This section provides information on the cables used to connect the SmartNode to the existing network infrastructure and to third party products.

Serial Console

The SmartNode can be connected to a serial terminal over its serial console port, as depicted in figure 12.



The interconnecting cables shall be acceptable for external use and shall be rated for the proper application with respect to voltage, current, anticipated temperature, flammability, and mechanical serviceability.



For the ISDN connection to a carrier network, it shall be connected to a network termination device and not connected directly to an outside POTS line.

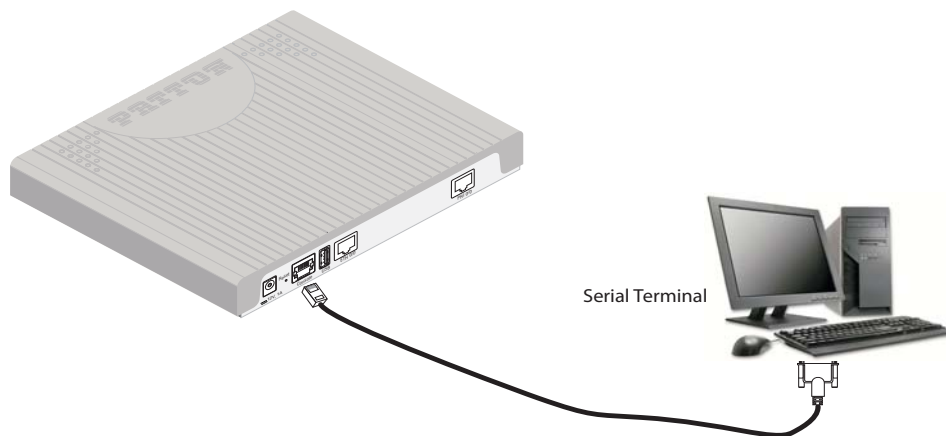

Note A Patton Model 16F-561 RJ45 to DB-9 adapter is included with each SmartNode Series device

Figure 12. Connecting a serial terminal

Console Connection settings:

- 19200 Bps
- 8bits, no parity
- 1stop bit
- flow control off

Note See section “Console port” on page 51 for console port pin-outs.

Ethernet

Ethernet devices (10/100/1000 Base-T) are connected to the SmartNode over a cable with RJ-45 plugs. The Ethernet port on the SN4170 is Auto-MDX. Use any straight or crossover cable to a host, hubs, switches, PCs or other devices.



The interconnecting cables shall be acceptable for external use and shall be rated for the proper application with respect to voltage, current, anticipated temperature, flammability, and mechanical serviceability.



For the ISDN connection to a carrier network, it shall be connected to a network termination device and not connected directly to an outside POTS line.

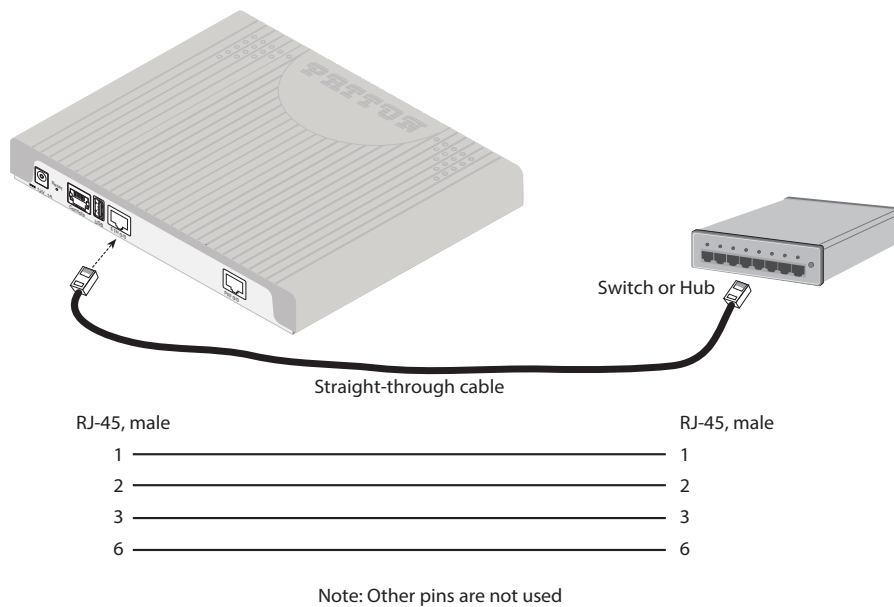

Figure 13. Typical Ethernet straight-through cable diagram for 10/100Base-T

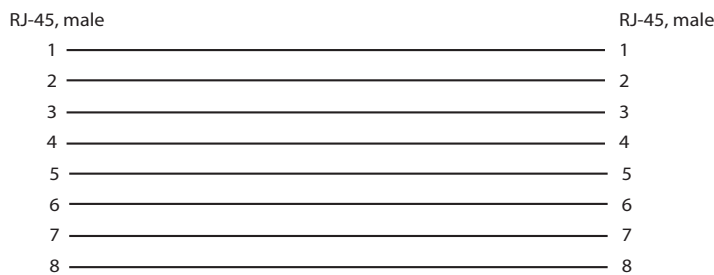

Figure 14. Typical Ethernet straight-through cable diagram for 1000Base-T

ISDN PRI (E1/T1)

The E1/T1 PRI port 0/0 uses the (LE) pinout. In most cases, a straight-through RJ-45 to RJ-45 can be used to connect the device to a PSTN NT. However, pinouts may vary depending on the pinout being used by the NT.

If PRI port 0/0 will be connected to a PBX, usually a PRI cross-over cable is required.

See the cabling details in [figure 15](#).

The pin-out of a cross-over cable is illustrated in [figure 16](#)



Hazardous network voltages are present in the PRI cables. If you detach the cable, detach the end away from the SmartNode or interface card first to avoid possible electric shock. Network hazardous voltages may be present on the device in the area of the PRI port, regardless of when power is turned OFF.



To prevent damage to the system, make certain you connect the PRI cable to the PRI port only and not to any other RJ-45 socket.

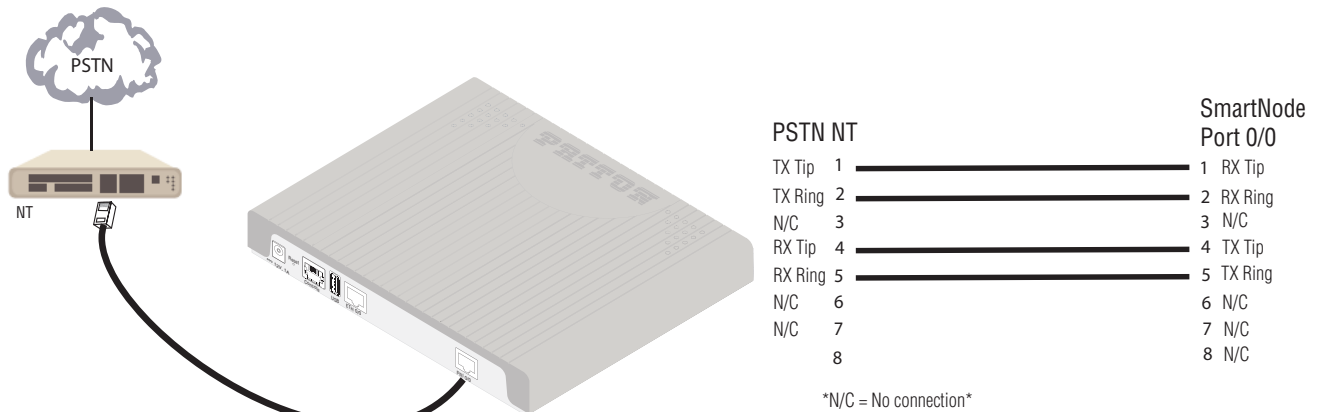

Figure 15. PSTN NT Cabling

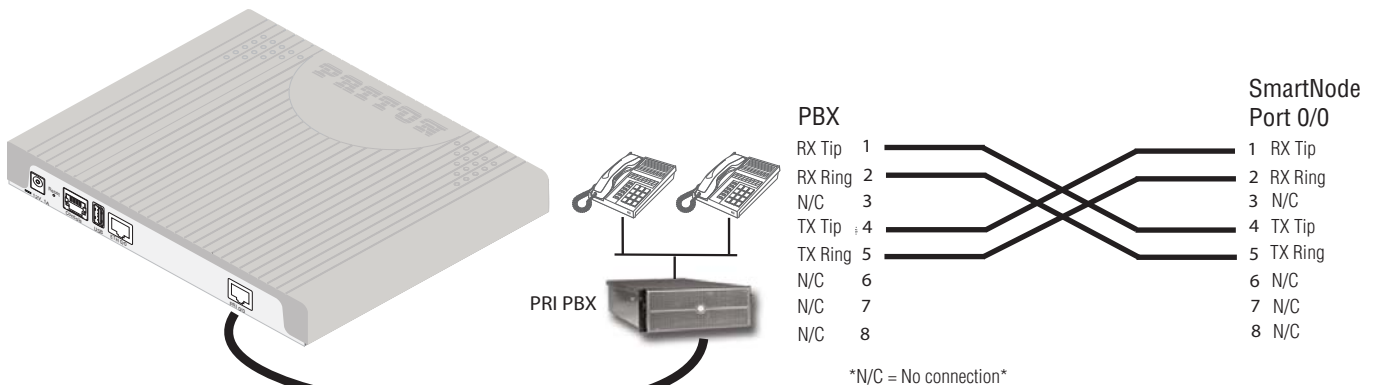

Figure 16. Crossover cable pinout

Appendix D **Port pin-outs**

Chapter contents

Introduction.....	51
Console port.....	51
Ethernet	51
ISDN PRI (E1/T1) Port Pin-outs.....	52

Introduction

This section provides pin-out information for the ports of the SmartNode.

Console port

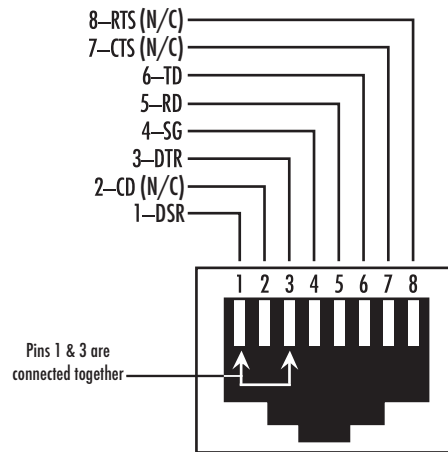

Figure 17. EIA-561 (RJ-45 8-pin) port

Note N/C means no internal electrical connection.

Console Connection Settings:

- 19200bps
- 8 bits, no parity
- 1 stop bit
- flow controls off

Ethernet

Table 7. 10/100 Base-T RJ-45 socket

Pin	Signal
1	TX+
2	TX-
3	RX+
6	RX-

Note Pins not listed are not used.

Table 8. 1000Base-T RJ-45 Socket

Pin	Signal
1	TRD0+
2	TRD0-
3	TRD1+
4	TRD1-
5	TRD2+
6	TRD2-
7	TRD3+
8	TRD3-

ISDN PRI (E1/T1) Port Pin-outs

Table 9. Port 0/0

Pin	Signal
1	RX_TIP
2	RX_RING
3	NC
4	TX_TIP
5	TX_RING
6	NC
7	NC
8	NC

Note Pins not listed are not used

Appendix E **SmartNode SN4170 Factory Configuration**

Chapter contents

Introduction.....	54
-------------------	----

Introduction

The factory configuration settings for SmartNode SN4170 can be obtained with the following command through the CLI;

```
login: admin
password: <Enter>
192.168.1.1>show config:shipping-config
```

Please see Chapter 4, "[Initial Configuration](#)" on page 27 for more details about IP address settings for initial configuration.

Appendix F **Reset Button Functions**

Chapter contents

Introduction.....	56
Resetting the SmartNode device when it is operating and the Power LED is lit.....	56
Resetting the SmartNode device when it is initially powered off.....	57

Introduction

The *Reset* button (see [figure 18](#)) is used to do the following:

- Reboot the SmartNode device (see section “Resetting the SmartNode device when it is operating and the Power LED is lit”)
- Erase the *startup-config* settings, which is followed by a SmartNode device reboot as indicated by the slow blinking of all LEDs (see section “Resetting the SmartNode device when it is operating and the Power LED is lit”)
- Factory reset, which is followed by a device reboot as indicated by the fast blinking of all LEDs (see section “Resetting the SmartNode device when it is operating and the Power LED is lit”)
- Troubleshoot the SmartNode device if it is not booting properly (see section “Resetting the SmartNode device when it is initially powered off” on page 57)

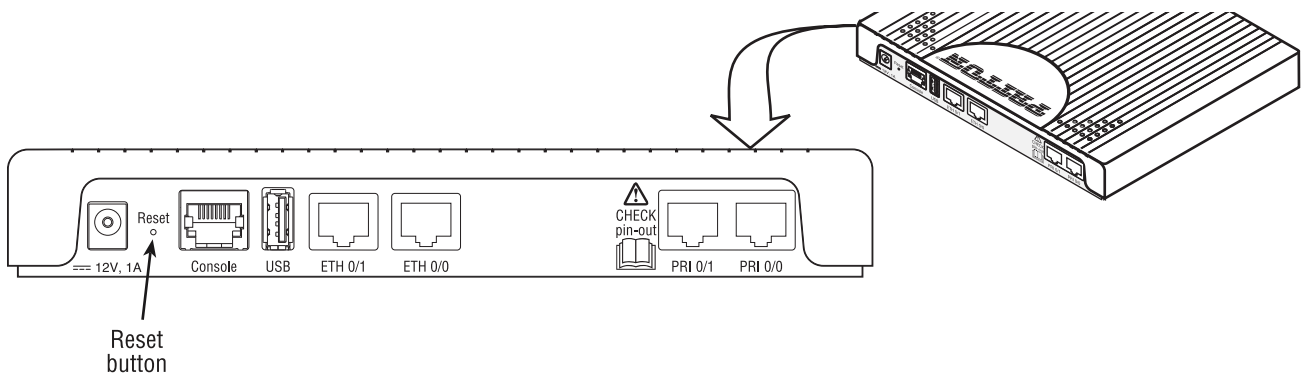

Figure 18. Reset button

Resetting the SmartNode device when it is operating and the Power LED is lit

The *Reset* button has the following behaviors depending on how many seconds (see [figure 19](#)) the button is pressed (see [table 10](#) on page 56 for the results from pressing the button).

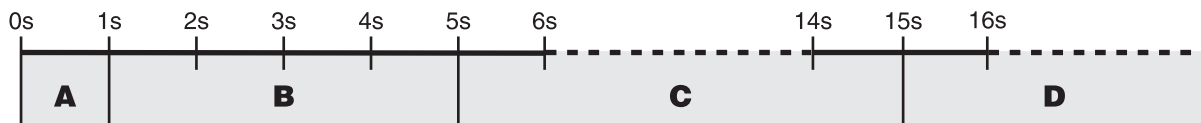

Figure 19. Reset button periods (in seconds) for performing actions

Table 10. Results from pressing the Reset button

Period	Action
A (less than 1 second)	Reboot device
B (1 to 4 seconds)	No action

Table 10. Results from pressing the Reset button (Continued)

Period	Action
C (5 to 14 seconds)	<ul style="list-style-type: none"> • Erase <i>startup-config</i> • Reboot (indicated by the slow blinking of all LEDs)
D (15 to 20 seconds)	<ul style="list-style-type: none"> • Factory reset which erases entire flash memory except for <i>shipping-config</i>, shipping wizards, default root CAs and software licenses • Reboot (indicated by fast blinking of all LEDs)

Resetting the SmartNode device when it is initially powered off



This procedure should **only** be performed if the SmartNode device is not booting properly. It should be used by trained SmartNode technicians and Patton Support personnel only.

If the SmartNode device is not booting properly, the *Reset* button may remedy the problem as follows:

- Switching to the backup image
- Erasing the entire contents of flash memory (no exceptions)

The following procedure must be performed starting with the SmartNode device in a powered off state:

1. Hold the *Reset* button and
2. Apply power to the SmartNode device while holding the *Reset* button.
3. The *Power* LED flashes quickly for 2 seconds, during which time the *Reset* button must remain pressed.
4. The *Power* LED will begin a blink pattern (see [table 11](#)). Release the *Reset* button.

Table 11. Using the Reset button to switch to a backup image or erase flash memory

LED Blink Pattern	Action
1-blink, pause	Boot normally
2-blinks, pause	Switch to backup image, then boot (boot normally if the device only has a single image).
3-blinks, pause	Erase entire contents of flash memory (no exceptions), then boot. Note Erasing flash memory also deletes previously purchased and loaded software license keys.

5. Pressing and releasing the *Reset* button will cycle through the blink patterns.
6. 10 seconds after the last *Reset* button press, an action will be performed based on the selected pattern.

Appendix G **End User License Agreement**

Chapter contents

- End User License Agreement 59
 - 1. Definitions 59
 - 2. Title 59
 - 3. Term 59
 - 4. Grant of License 59
 - 5. Warranty 60
 - 6. Termination 60
 - 7. Notices 60
 - 8. Other Licenses 60
 - 9. Unenforceable Provisions 61
 - 10. Governing Law 61
 - 11. Waiver 61

End User License Agreement

By opening this package, operating the Designated Equipment or downloading the Program(s) electronically, the End User agrees to the following conditions:

1. Definitions

- A) “Effective Date” shall mean the earliest date of purchase or download of a product containing the Patton Electronics Company Program(s) or the Program(s) themselves.
- B) “Program(s)” shall mean all software, software documentation, source code, object code, or executable code.
- C) “End User” shall mean the person or organization which has valid title to the Designated Equipment.
- D) “Designated Equipment” shall mean the hardware on which the Program(s) have been designed and provided to operate by the End User.

2. Title

Title to the Program(s), all copies of the Program(s), all patent rights, copyrights, trade secrets and proprietary information in the Program(s), worldwide, remains with Patton Electronics Company or its licensors.

Patton does not convey any intellectual property title or rights in the Licensed Products to Licensee. All Licensed Products furnished by Patton, and all copies thereof, and compilations, programmatic extension, and all Patches, Updates, Upgrades and Platform Releases, are and shall remain the property of Patton or Patton’s licensors, as applicable. Further, the Licensed Products provided under this Agreement are not custom software but are standard commercial software. Except for the license use rights otherwise expressly provided in this Agreement, no right, title or interest in Patton Licensed Products is granted hereunder. Licensee shall not use any proprietary information of Patton to create any computer software program or user documentation, which is substantially similar to the Licensed Products.

3. Term

The term of this Agreement is from the Effective Date until title of the Designated Equipment is transferred by End User or unless the license is terminated earlier as defined in section “6. Termination” on page 60.

4. Grant of License

- A) During the term of this Agreement, Patton Electronics Company grants a personal, non-transferable, non-assignable and non-exclusive license to the End User to use the Program(s) only with the Designated Equipment at a site owned or leased by the End User.
- B) The End User may copy licensed Program(s) as necessary for backup purposes only for use with the Designated Equipment that was first purchased or used or its temporary or permanent replacement.
- C) The End User is prohibited from disassembling; decompiling, reverse-engineering or otherwise attempting to discover or disclose the Program(s), source code, methods or concepts embodied in the Program(s) or having the same done by another party.
- D) Should End User transfer title of the Designated Equipment to a third party after entering into this license agreement, End User is obligated to inform the third party in writing that a separate End User License Agreement from Patton Electronics Company is required to operate the Designated Equipment.

5. Warranty

The Program(s) are provided “as is” without warranty of any kind. Patton Electronics Company and its licensors disclaim all warranties, either express or implied, including but not limited to the implied warranties of merchantability, fitness for a particular purpose or non-infringement. In no event shall Patton Electronics Company or its licensors be liable for any damages whatsoever (including, without limitation, damages for loss of business profits, business interruption, loss of business information, or other pecuniary loss) arising out of the use of or inability to use the Program(s), even if Patton Electronics Company has been advised of the possibility of such damages. Because some states do not allow the exclusion or limitation of liability for consequential or incidental damages, the above limitation may not apply to you.

If the Program(s) are acquired by or on behalf of a unit or agency of the United States Government, the Government agrees that such Program(s) are “commercial computer software” or “computer software documentation” and that, absent a written agreement to the contrary, the Government’s rights with respect to such Program(s) are limited by the terms of this Agreement, pursuant to Federal Acquisition Regulations 12.212(a) and/or DEARS 227.7202-1(a) and/or sub-paragraphs (a) through (d) of the “Commercial Computer Software—Restricted Rights” clause at 48 C.F.R. 52.227-19 of the Federal Acquisition Regulations as applicable.

6. Termination

- A) The End User may terminate this agreement by returning the Designated Equipment and destroying all copies of the licensed Program(s).
- B) Patton Electronics Company may terminate this Agreement should End User violate any of the provisions of section “4. Grant of License” on page 59.
- C) Upon termination for A or B above or the end of the Term, End User is required to destroy all copies of the licensed Program(s)

7. Notices

Patton devices may log, collect and report data related to installed software, licenses, feature utilization, product performance, device management, service quality and other parameters which is used for quality control, product improvement, license management, service level management and technical support. Collected data may be reported to Patton or a service provider delivering its services connected to the device.

Patton may use this information for other business purposes, such as to alerting you to updated products or services, securing access to software updates, and assisting in order processing.

Any and all information collected by Patton or its assigns will be kept strictly confidential and will not be sold, rented, loaned, or otherwise disclosed to any third party except as required by law.

8. Other Licenses

The Program may be subject to licenses extended by third parties. Accordingly, Patton Electronics Company licenses the Programs subject to the terms and conditions dictated by third parties. Third party software identified to the Programs includes:

- The LGPL (Lesser General Public License) open source license distributed to you pursuant to the LGPL license terms (<http://www.gnu.org/licenses/lgpl.html>).
- RedBoot (Red Hat Embedded Debug and Bootstrap) embedded system debug/bootstrap environment from Red Hat distributed to you pursuant to the eCos license terms (ecos.sourceware.org/license-overview.html) and GNU General Public License (GPL) terms (www.gnu.org/copyleft/gpl.html). Source code is available upon request.

9. Unenforceable Provisions

If any part of these terms and conditions are found to be invalid or unenforceable under applicable law, such part will be ineffective to the extent of such invalid or unenforceable part only, without in any way affecting the remaining parts of these terms and conditions.

10. Governing Law

The rights and obligations of the parties pursuant to these terms and conditions are governed by, and shall be construed in accordance with, the laws of the State of Maryland, USA.

User may be subject to other local, provincial or state and national laws. User hereby irrevocably submits to the exclusive jurisdiction of the courts of the State of Maryland, USA for any dispute arising under or relating to this agreement and waives user's right to institute legal proceedings in any other jurisdiction. Patton shall be entitled to institute legal proceedings in connection with any matter arising under this agreement in any jurisdiction where User resides, does business, or has assets.

11. Waiver

No waiver of any of the provisions of these terms and conditions will be deemed to constitute a waiver of any other provision *nor shall such a waiver constitute a continuing waiver unless otherwise expressly provided in writing duly executed by the party to be bound thereby*. Any other terms and conditions of sale, to the extent not inconsistent herein, regarding a Patton device, program, license or service remain in full force and effect.